

Collet chucks SK30 + SK40 DIN 69871 without grooves and notches / ISO30 / SK30 SCM with gear ring with ball bearing clamping nut

item number	taper size	collet form	A [mm]	D1 [mm]	D2 [mm]	matching collets (clamping-Ømm)
30.125.050.060	SK30	ER25	50	50	42	430E (Ø1-16)
30.132.050.060	SK30	ER32	50	50	50	470E (Ø2-20)
30.140.057.060	SK30	ER40	57	50	63	472E (Ø3-26)
30.140.063.060	SK30	ER40	63	50	63	472E (Ø3-26)
30.225.071.080	SK30	OZ1825	71	50	60	462E (Ø2-25)
40S.132.050.060	SK40	ER32	50	63,55	50	470E (Ø2-20)
40S.140.063.060	SK40	ER40	63	63,55	63	472E (Ø3-26)
40S.225.070.080	SK40	OZ1825	70	63,55	60	462E (Ø2-25)
30I.132.050.060	ISO30	ER32	50	46	50	470E (Ø2-20)
30I.132.055.060	ISO30	ER32	55	46	50	470E (Ø2-20)
30I.132.060.060	ISO30	ER32	60	46	50	470E (Ø2-20)
30I.140.064.060	ISO30	ER40	64	46	63	472E (Ø3-26)
30I.225.070.080	ISO30	OZ1825	70	46	60	462E (Ø2-25)
with gear ring						
30SCM.132.055.060	SK30 SCM	ER32	55	50	50	470E (Ø2-20)
30SCM.225.072.080	SK30 SCM	OZ1825	72	50	60	462E (Ø2-25)

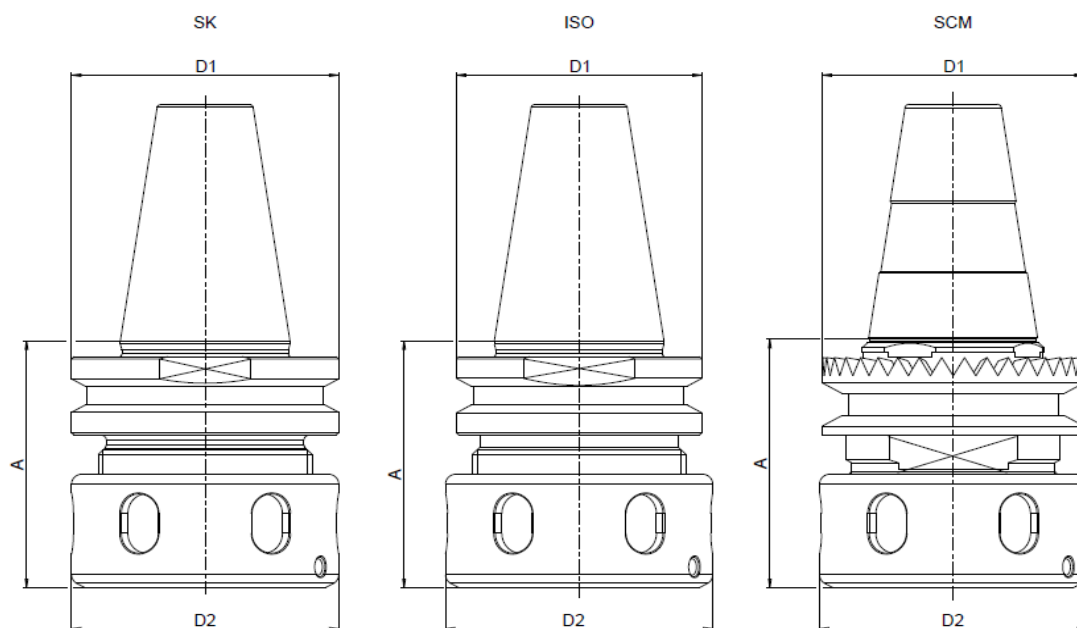

Collets are not included